

11-50

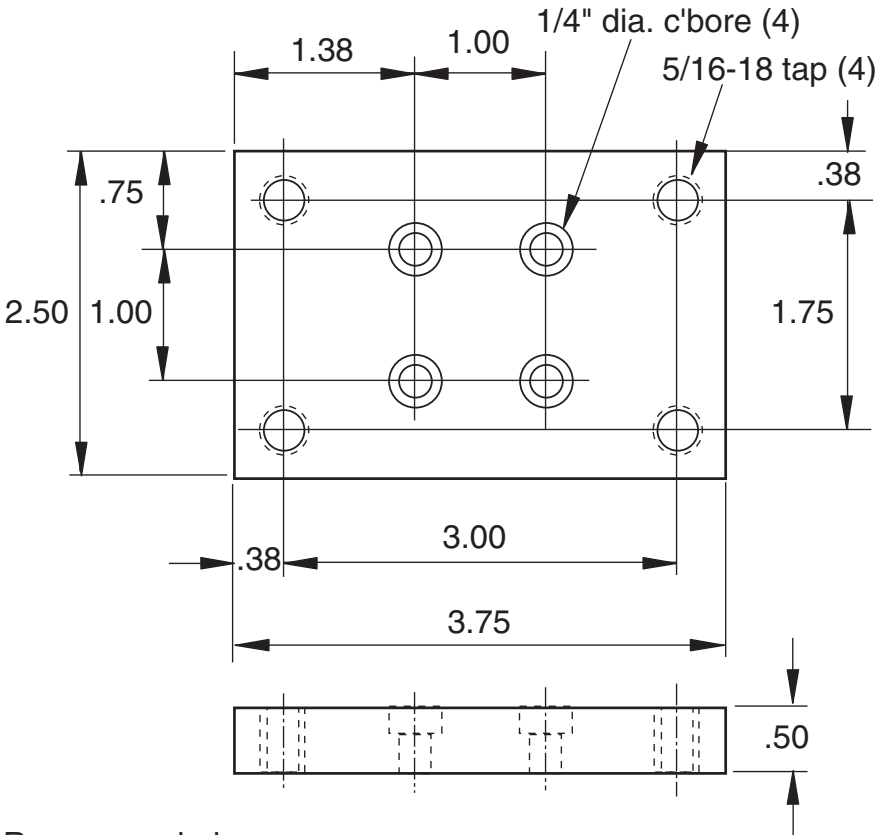

1/4" SLOTS

Recommended Hardware

- (4) 11-221 SHCS for extrusion end mounting
- or
- (4) 11-223 SHCS for extrusion slot mounting
- (4) 11-210 T-nut

For Casters, See Pages 427 & 428

Material - Aluminum
 Finish - Clear Anodize