

Leveling Anchor Plate

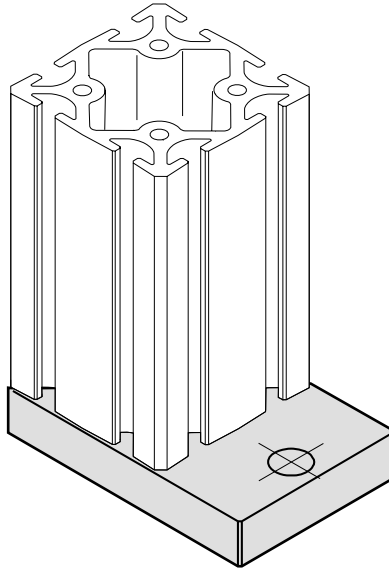

EBP-3
EBP-3A
EBP-3B
EBP-3C



5/16" SLOTS

EBP-3	thread 1/2-13
EBP-3A	3/8-16
EBP-3B	5/8-11
EBP-3C	3/4-10

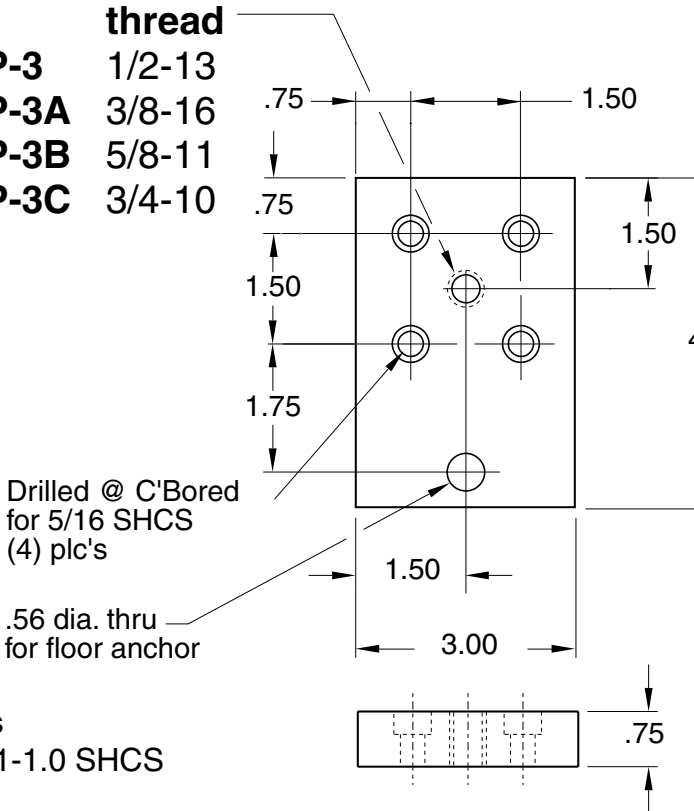

Requires
(4) EF-11-1.0 SHCS

Material - Aluminum
Finish - Clear Anodize